



Flyback Transformer

AEF20-3648

- EF20 Ferrite Core Design
- 10 Pin Through Hole
- Flyback Topology

Electrical Specifications @ 25°C			
INDUCTANCE @10KHz / 0.23V HP-4284A	LEAKAGE INDUCTANCE 100KHz / 0.23V HP-4284A	POLARITY 10KHz / 1.0V	GAP
3 - 1 : 1.0 mH ±10% @ 0ADC	3 - 1: 13.0uH MAX.	PER SCHEMATIC	CORE MYLAR FILM GAP
3 - 1 : 0.8 mH MIN. @ 0.65 ADC	(SHORTED 4,5,6,7,8,9)		
DCR @ 25°C (CH-502A)	URNS RATIO IN PROCESS TEST USING UNGAPPED CORES	HI-POT TEST	
3 - 2 : 930mOHM MAX	(3 - 2) : (2 - 1) ; 1 : 1 = 1.00±2%	(1,2,3,4,5) TO (6,7,8,9): AC 3000V 3mA FOR 1 MINUTE	
9 - 8 : 130mOHM MAX	(3 - 1) : (4 - 5) ; 4.25 : 1 = 4.42±2%	(1,2,3,4,5) TO CORE: AC 3000V 3mA FOR 1 MINUTE	
4 - 5 : 485mOHM MAX	(3 - 1) : (6 - 7) ; 16.8 : 1 = 16.80±2%	(6,7,8,9) TO CORE: AC 1500V 3mA FOR 1 MINUTE	
6 - 7 : 15.25mOHM MAX	(3 - 1) : (9 - 8) ; 5.6 : 1 = 5.60±2%		
2 - 1 : 1300mOHM MAX			

All specifications subject to change without notice.

MECHANICAL

DIMENSION:
UNIT: inch

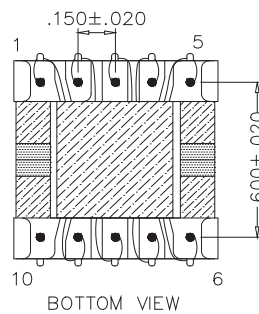
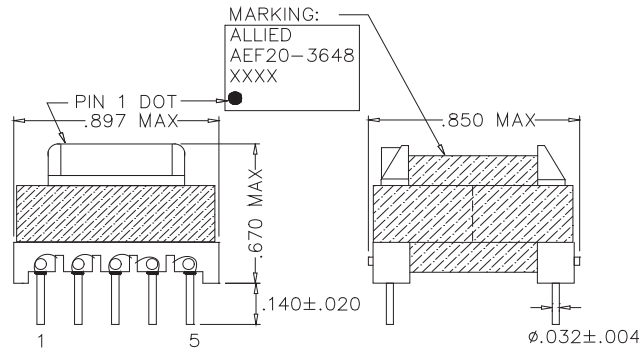

NOTE:
1. MARKING & DOT :

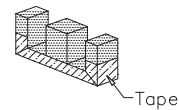

- CORE TAPE FIX 2TS.
- TOP AND BOTTOM SIDE CORE MUST AFFIXED 2 LAYER TAPE.

WINDING:

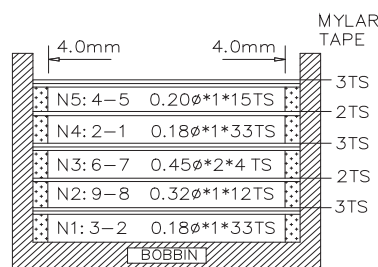

SCHEMATIC:

