

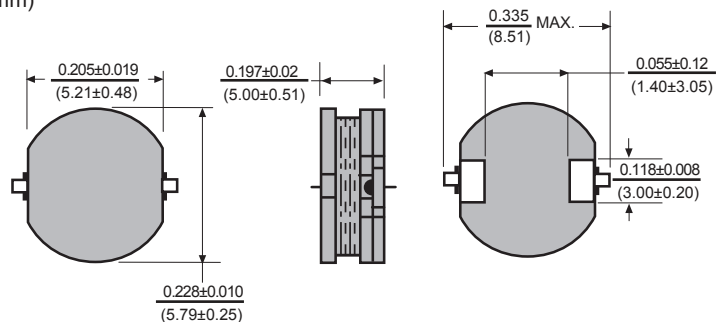

Dimensions: $\frac{\text{Inches}}{\text{(mm)}}$



Allied Part Number	Inductance (μH)	Tolerance (%)	Test Freq. (MHz)	DCR Max. (Ω)	*Rated Current (A)
PC25-100M-RC	10	20	2.52	0.10	1.44
PC25-120M-RC	12	20	2.52	0.12	1.40
PC25-150M-RC	15	20	2.52	0.14	1.30
PC25-180M-RC	18	20	2.52	0.15	1.23
PC25-220M-RC	22	20	2.52	0.18	1.11
PC25-270M-RC	27	20	2.52	0.20	0.97
PC25-330L-RC	33	15	2.52	0.23	0.88
PC25-390L-RC	39	15	2.52	0.32	0.80
PC25-470L-RC	47	15	2.52	0.37	0.72
PC25-560K-RC	56	10	2.52	0.42	0.68
PC25-680K-RC	68	10	2.52	0.46	0.61
PC25-820K-RC	82	10	2.52	0.60	0.58
PC25-101K-RC	100	10	1KHz	0.70	0.52
PC25-121K-RC	120	10	1KHz	0.93	0.48
PC25-151K-RC	150	10	1KHz	1.10	0.40
PC25-181K-RC	180	10	1KHz	1.38	0.38
PC25-221K-RC	220	10	1KHz	1.57	0.35

*Inductance drop no more than 10% at rated current applied or temperature rise $\Delta T = 40^\circ\text{C}$. All specifications subject to change without notice.

Features

- Small size allows for high mounting density
- Suitable for Reflow Solder
- Large DC current capability with low DC resistance
- Embossed carrier tape available
- Polarity identification available
- Custom inductances available

Characteristics

Operating Temp.: -30° to $+100^\circ\text{C}$.

External Appearance: Clean & no external defects by visual inspection

Terminal Strength: After soldering, push the coils will withstand the followings without falling off. 20.0N 20 sec.

Heat Endurance: Heat at 150°C for 3 minutes; then 200°C for 25 seconds. No mechanical or electrical defect after that when back at room temperature.

Insulation: Over 100M ohm at 100 VDC (coil and core).

Dielectric: 100VDC for one minute (coil and core).

Temperature Characteristics: (0 to 2000) $\times 10^{-6}^\circ\text{C}$.

Environmental

Humidity: Deviate $\pm 5\%$, after 96 hours in 90-95% relative humidity at 40°C and 1 hour of drying.

Vibration: Deviate $\pm 5\%$, vibration of 1 hour, three direction; 10-55-10 Hz; 1.5mm p-p amplitude.

Shock: Deviate 5% after drop down 100G shock attitude of one time in each direction.

Physical

Packaging: 1000 per 13 inch reel.