



- 10/100 Base-T Ethernet Application
- Impedance: 100OHMS
- Transmit open circuit inductance (OCL): 350uH (MIN) @100KHz,0.1VRMS with 8mA DC Bias
- RJ45 jack cavity conforms to FCC rules and regulations Part 68, SUB Part F
- Standard operating temp: 0°C to +70°C
- Storage temperature range: -40°C to +85°C

Electrical Specifications @ 25°C

Part Number	OCL(uH Min) @ 100kHz, 0.1V With 8mA DC Bias	Turns Ratio chip: cable (±3%)	Insertion Loss (dB Max)	Return Loss (dB Min)		
	30MHz		50MHz	80MHz		
AR24-3634-1	350	1CT:1CT	-1.0	-18	-15	-12

Electrical Specifications @ 25°C

Part Number	Cross Talk (dB Min)			CMR (dB Min)			HI-POT (VDC) 0.5mA/2Sec.
	30MHz	60MHz	100MHz	30MHz	60MHz	100MHz	
AR24-3634-1	-38	-38	-38	-40	-40	-40	1500

All specifications subject to change without notice.

MECHANICAL

AR24-3634-1

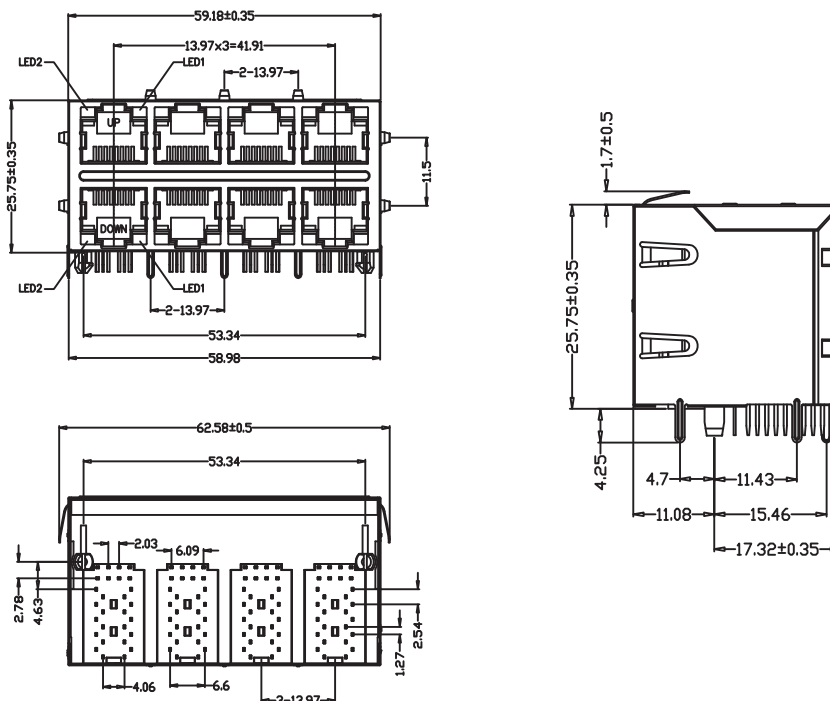



**SCHEMATICS**

AR24-3634-1

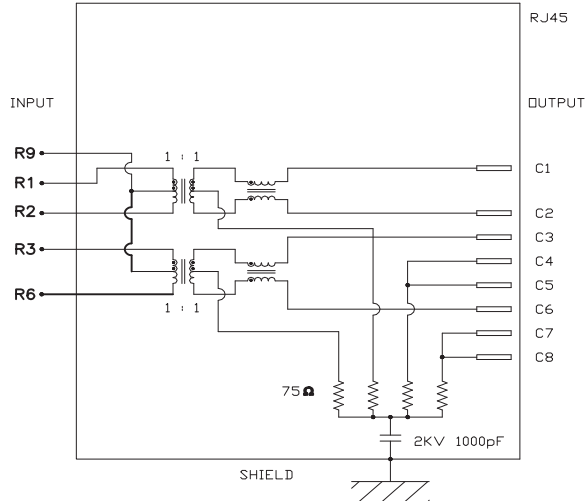

**LED CONFIGURATION**



**PCB LAYOUT**

AR24-3634-1

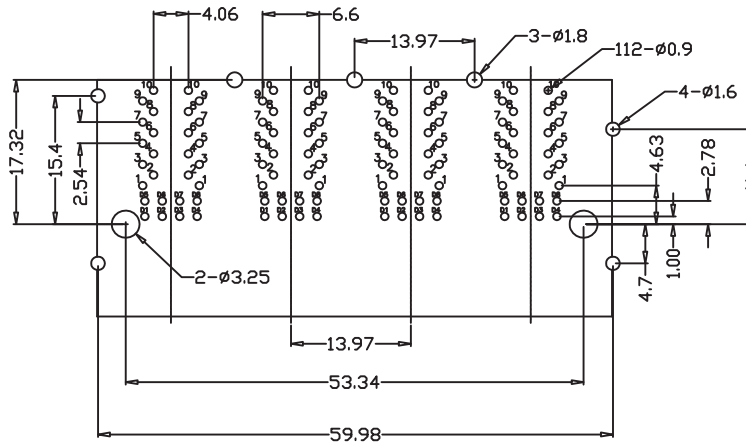

RECOMMENDED PCB LAYOUT COMPONENT SIDE  
ALL DIMENSION TOLERANCE ARE ±0.05 UNLESS OTHERWISE SPECIFIED

**NOTES**

1. Shield- 0.20mm THICKNESS BRASS C2680 H.  
PLATING NICKEL 30u"-50u"
2. Housing- Standard Material Nylon 66, Glass filled  
Polyester UL94V-0 Standard Color Black.
3. RJ Terminal- Plastic: PBT+30% GF UL94V-0, Standard  
Color Black.  
Pin: 0.35mm Thickness Phos-Bronze C5210 EH.  
Plating: Nickel 40u"-60u" for all Sn 100%, and  
6u" Gold Plating.
4. Contact Pin- Plastic: Nylon 66, Glass Filled, UL94V-0,  
Standard Color Black.  
Pin: 0.35mm Thickness Phos-Bronze C2680.  
Plating: Nickel 40u"-60u" for all Sn 100%.